



FRANCE DESIGNED

Saturn

Stroller

USER MANUAL

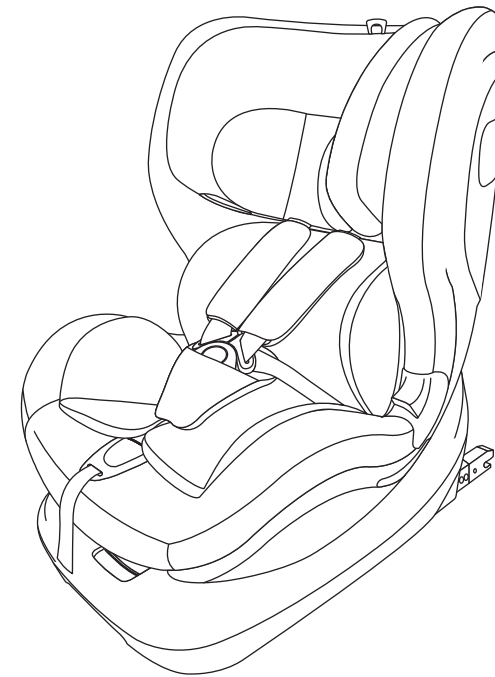

www.jikelbaby.com

IMPORTANT

Retain for Future Reference & Read Carefully



Thank you for trust to our company and products!

For parents:

Welcome to use Saturn car seats. Please read user manual carefully before installing and using.

1. ISOFIX SEMI-UNIVERSAL 0+I (0-18KG): ISOFIX+TOP TETHER+HARNESS



Notice

1. This is ISOFIX CHILD RESTRAINT SYSTEM. It is approved to Regulation No.44,04 series of amendments for general use in vehicles fitted with ISOFIX anchorages systems.
2. It will fit vehicles with positions approved as ISOFIX positions(as detailed in the vehicle handbook), depending on the category of the child seat and of the fixture.
3. The mass group and ISOFIX size class for which this device is intended is: 0+Igroup, 0-18kg, ISOFIX D.

This Child restraint is classified for“(Semi-Universal)”use and is suitable for fixing into the seat positions of the following cars:

CAR	FRONT	REAR	
(Apply to all vehicles with ISOFIX anchorages)	Outer	Outer	Center
	No	Yes	?

Seat positions in other cars may also be suitable to accept this child restraint. If in doubt, consult either the child restraint manufacturer or the retailer.

Only can apply to the vehicle that has ISOFIX anchorages and 3-point safety belts.

WARNING: Don't use force-bearing points without marking!

2. ISOFIX UNIVERSAL I (9-18KG): ISOFIX+TOP TETHER+HARNESS

Notice

1. This is ISOFIX CHILD RESTRAINT SYSTEM. It is approved to Regulation No.44,04 series of amendments for general use in vehicles fitted with ISOFIX anchorages systems.
2. It will fit vehicles with positions approved as ISOFIX positions(as detailed in the vehicle handbook), depending on the category of the child seat and of the fixture.
3. The mass group and ISOFIX size class for which this device is intended is: I group, 9-18kg, ISOFIX B1.

Notice

- 1.This is a “Universal”child restraint. It is approved to Regulation No.44, 04 series of amendments, for general use in vehicles and it will fit most, but not all, car seats.
2. A correct fit is likely if the vehicle manufacturer has declared in the vehicle handbook that the vehicle is capable of accepting a “Universal”child restraint for this age group.
- 3.This child restraint has been classified as “Universal”under more stringent conditions than those which applied to earlier designs which do not carry this notice.
- 4.If in doubt, consult either the child restraint manufacturer or the retailer.

- ⚠ The vehicle equipped with ISOFIX anchorages.
- ⚠ **WARNING: Don't use forward facing before the child's weight exceeds 9kg!**

3. SEMI-UNIVERSAL II+III (15-36kg): ISOFIX+3-POINT BELT



This Child restraint is classified for “(Semi-Universal)”use and is suitable for fixing into the seat positions of the following cars:

CAR	FRONT	REAR	
(Apply to all vehicles with ISOFIX anchorages)	Outer	Outer	Center
	No	Yes	?

Seat positions in other cars may also be suitable to accept this child restraint. If in doubt, consult either the child restraint manufacturer or the retailer.

? Only can apply to the vehicle that has ISOFIX anchorages and 3-point safety belts.

- ⚠ Only suitable for use in the listed vehicles fitted 3 point/with retractor safety-belts, approved to ECE Regulation No.16.
- ⚠ The vehicle equipped with ISOFIX anchorages.

4. UNIVERSAL II+III (15-36kg): 3-POINT BELT



Notice

- 1.This is a “Universal”child restraint. It is approved to Regulation No.44, 04 series of amendments, for general use in vehicles and it will fit most, but not all, car seats.
2. A correct fit is likely if the vehicle manufacturer has declared in the vehicle handbook that the vehicle is capable of accepting a “Universal”child restraint for this age group.

3.This child restraint has been classified as“Universal”under more stringent conditions than those which applied to earlier designs which do not carry this notice.

4.If in doubt, consult either the child restraint manufacturer or the retailer.

⚠ Only suitable for use in the listed vehicles fitted 3 point/with retractor safety-belts, approved to ECE Regulation No.16.

WARNING

1. The steel components and plastic components of safety seat have to be fixed by referring to manual, which ensure safety seat not be stuck by car seats and car doors.
2. Any straps holding the restraint to the vehicle should be tight, that any straps restraining the child should be adjusted to the child's body, and that straps should not be twisted.
3. Any lap strap is worn low down, so that the pelvis is firmly engaged, shall be stressed.
4. It can not be used when it has been subject to violent stresses in an accident.
5. It's dangerous to make any alterations or additions to the chair without the approval of the Type Approval Authority, and it is a danger of not following closely the installation instructions provided by the child restraint manufacturer.
6. The chair should be kept away from sunlight, otherwise it may be too hot for the child's skin.
7. Please do not leave your child in their child restraint system unattended.
8. Any luggage or other objects liable to cause injuries in the event of a collision shall be properly secured.
9. a: The child restraint shall not be used without the cover.
b: The seat cover should not be replaced with any other than the one recommended by the manufacturer, because the cover constitutes an integral part of the restraint performance.
10. The instructions can be retained on the child restraint for its life period.
11. Do not use any load bearing contact points other than those described in the instructions and marked in the child restraint.
12. The rigid items and plastic parts of a child restraint shall be so located and installed that they are not liable, during everyday use of the vehicle, to become trapped by a movable seat or in a door of the vehicle.
13. Any luggage or other objects liable to cause injuries in the event of a collision shall be properly secured.
14. Safe driving is the best way to protect children, and children's safety seats can protect children effectively but cannot completely eradicate the harms of car accidents.
15. Please be sure to use the right Group of the children's seats with appropriate methods of application, which refer to the instructions manual of child restraint system. Otherwise, there is potential risk to cause child injuries.
16. The child safety seat must not be positioned anywhere where it is in range of an airbag which is being deployed, otherwise, once accident happened, airbag can hurt your child.
17. If there is mutual interference between the adult safety-belt buckle and the main load bearing contact points on the restraint, it cannot be used. The user shall be advised to contact the child restraint manufacturer if in doubt about this point.
18. Do not use forward facing before the child's weight exceeds 9kg.
19. Rearward facing can not be installed in the position which is equipped with airbag.
20. Keep the instruction for future use.

Table Of Contents

Know Your Car Seat (Front)	5
Know Your Car Seat (Opposite)	6
Selection Criteria for Baby Car Seat	7
Car Seat Function Introduction	8
Group 0+I (0-18kg) Installation (Rearward facing placement)	9
Group I (9-18kg) Installation (Forward facing placement)	13
5-Point Harness Removal	19
Group II+III (15-36kg) Installation and Using method	21
Removing the Cover	24
Cleaning and Maintenance	25

Know Your Car Seat (Front)

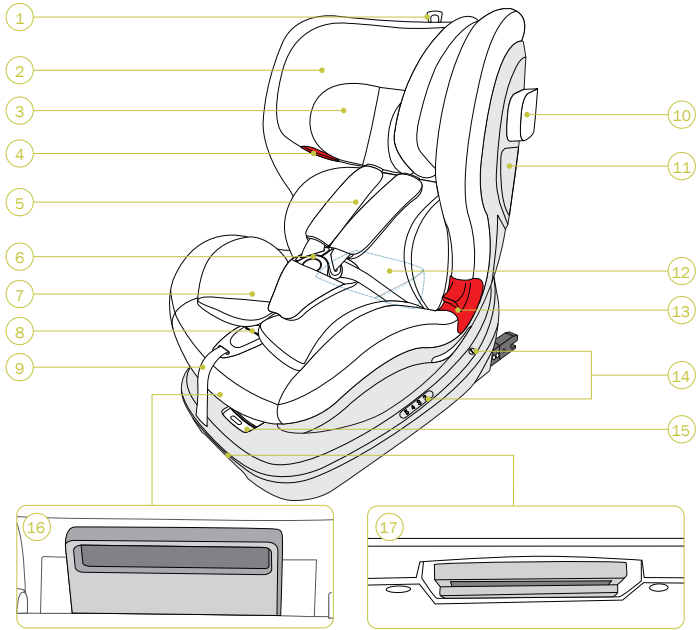

- | | | |
|--|---|---------------------------------------|
| ① Headrest setting handle | ⑦ Group I Cushion (Using by baby from 9-12kg) | ⑬ Harness Guider for Group II and III |
| ② Headrest | ⑧ Central Adjuster | ⑭ Gear Indicator for Setting posture |
| ③ Pillow (Using by baby < 9 kg) | ⑨ Harness Adjustment Strap | ⑮ Rotation Control Handle Strap |
| ④ Guide hook for Group II+III (Using by baby from 15-36kg) | ⑩ Side Protection | ⑯ Seat Position Adjustment Handle |
| ⑤ Shoulder Pads | ⑪ Installation Instruction | ⑰ ISOFIX Setting Handle |
| ⑥ Harness Buckle | ⑫ Group 0+ Cushion (Using by baby < 9 kg, collocate with Group I Cushion) | |



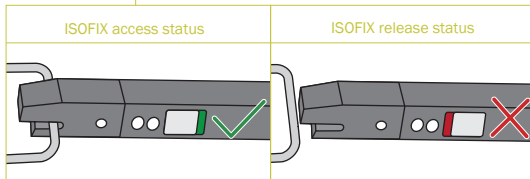
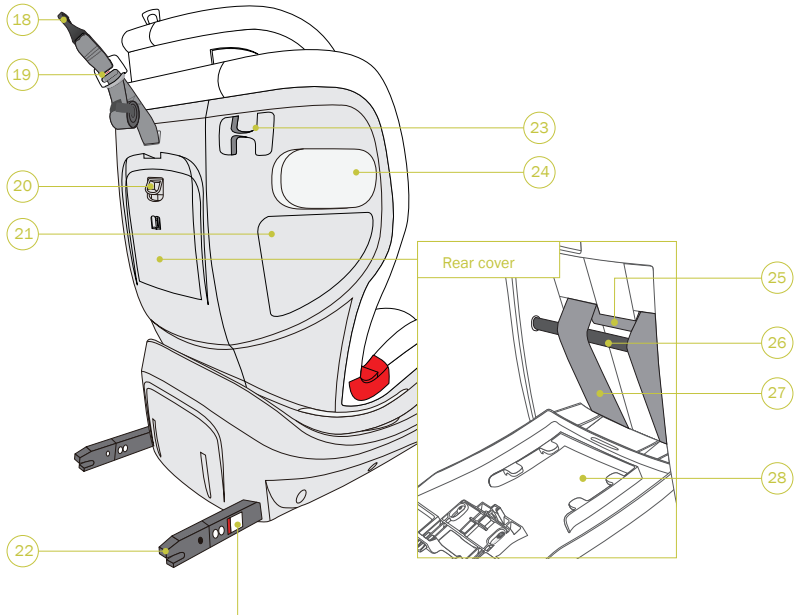

Know Your Car Seat (Opposite)



- 18 Top Tether Hook
- 19 Top Tether Adjuster
- 20 Rear Cover Button
- 21 Installation Instruction
- 22 ISOFIX Connector(G0+I)
ISOFIT Connector(GII+III)
- 23 Guiding slot for rearward facing
- 24 Side protection
- 25 Shoulder Connection Harness
- 26 Harness Shaft
- 27 Shoulder Harness Strap X2
- 28 Manual Storage Slot

Selection Criteria for Baby Car Seat

- This type baby car seat is applied to Group 0+ / I / II / III and the requirement for weight is from 0 to 36kg. It is suitable for around 0 to 12 year-old children. The vehicle should have ISOFIX system that meet the requirement of ECE R14.
- Different installation methods should be applied to children in different group. Please follow the below standards to match the right group installation.
- Do not use any load bearing contact points other than those described in the instructions and marked in the child restraint system.
- Baby car seat for rearward facing can not be installed in the position which is equipped with airbag. In the driving condition, baby car seat cannot be lateral using or rotated.

Group	Body weight	Age	Children's restraining system	Installation method	Direction of installation	Requirement for vehicles
0+	0-13kg	0-15 months	5-point harness	ISOFIX + top-tether	Rearward Facing 	The vehicle equipped with ISOFIX anchorages.
I	9-18kg	9months-3years old	5-point harness	ISOFIX + top-tether	Rearward Facing 	The vehicle equipped with ISOFIX anchorages.
I	9-18kg	9months-3years old	5-point harness	ISOFIX + top-tether	Forward Facing 	The vehicle equipped with ISOFIX anchorages.
II+III	15-36kg	4-12 years old	vehicle's 3-point seat belt	ISOFIX+ vehicle's 3-point seat belt	Forward Facing 	The vehicle equipped with ISOFIX anchorages, and cannot be used if the vehicle seat is equipped with only 2-point belt.
II+III	15-36kg	4-12 years old	vehicle's 3-point seat belt	vehicle's 3-point seat belt	Forward Facing 	The vehicle equipped with 3-point belt, and cannot be used if the vehicle seat is equipped with only 2-point belt.

 Only can apply to the vehicle that has ISOFIX anchorages and 3-point safety belts.

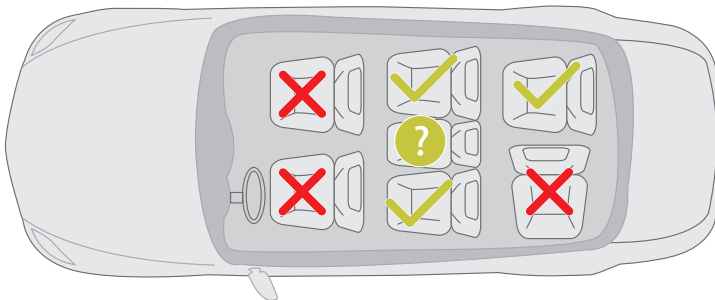

Car Seat Function Introduction

1. The Function of Rotation

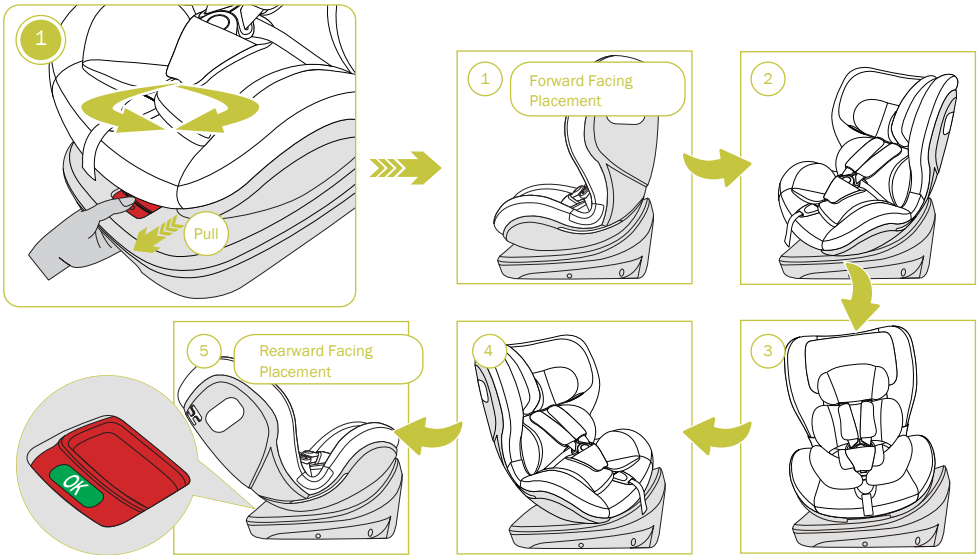

As shown in figure 1, using thumb pull the Rotation Control Handle to rotate the car seat. Both of two sides can be adjusted (See figure 1, 2, 3, 4, 5). When finishing rotation, release the Rotation Control Handle, it will show "OK" in the handle (See figure 5).

IMPORTANT: In the driving condition, baby car seat cannot be lateral using or rotated, it only can be fixed in the forward facing position (figure 1) and rearward position (figure 5).

2. The Function of Side Protection

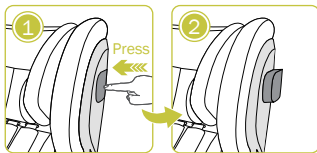

As shown in figure 1, when side protection is close, press it to open like figure 2. If you want to close it, you can press again to make it close like figure 1.

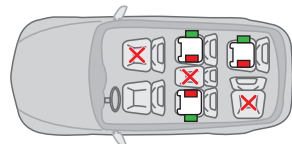

Red means the Side Protection is close.
Green means the Side Protection is open.

As shown in above figure, we suggest to open Side Protection one the side near the door. Users can choose open it or not according to your needs.

Group 0+I (0-18kg) Installation (Rearward facing placement)



ATTENTION:

1. Only suitable use in the listed vehicles fitted with ISOFIX anchorages systems and approved to ECE Regulation No. 14.
2. The installation for Group 0+I is rearward facing and is applied to children from 0 to 18kg.
3. This car seat for Group 0+I only has one sitting posture and it is level 1.
4. Baby car seat for Group 0+I can not be installed in the position which is equipped with airbag.
5. Important - If your child's weight is lighter than 9kg, you cannot make forward facing installation.
6. Important - In the driving condition, baby car seat cannot be lateral using.
7. **Children less than 9kg need to use 0+ group and 1 group cushion; children between 9-12kg need to use 1 group cushion without 0+ group cushion; children larger than 12kg do not need to use 0+ group cushion and 1 group cushion.**

1. ISOFIX Installation for Group 0+I

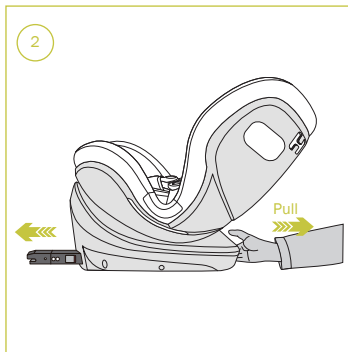
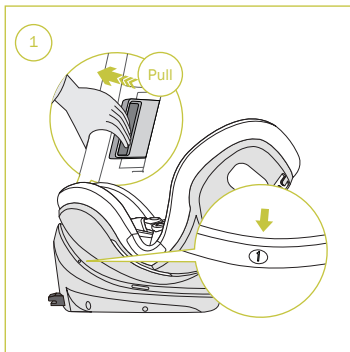

Step 1: As shown in figure 1, rotate car seat to rearward facing (Please refer to P8-The Function of Rotation). Then, pull the Seat Position Adjustment Handle to level 1.

Step 2: As shown in figure 2, release ISOFIX connector. Pull ISOFIX settingkey and ISOFIX connector will pop up automatically.

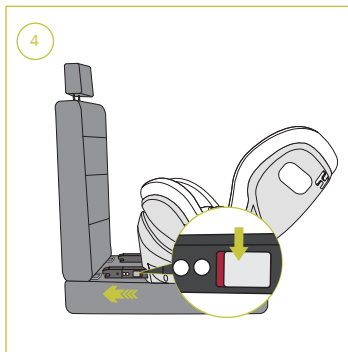
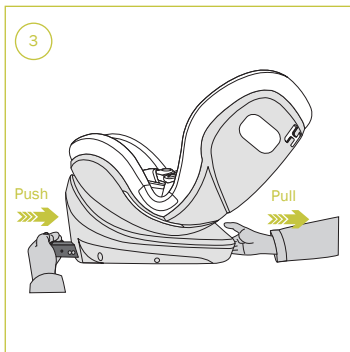

Step 3: As shown in figure 3, if you want to remove the ISOFIX, one hand pull the ISOFIX Setting Handle, the other hand press the ISOFIX connectors into the base.

Step 4: As shown in figure 4, before insert the two ISOFIX connectors into the ISOFIX fixed point, ISOFIX indication window is red.

Car Seat Function Introduction

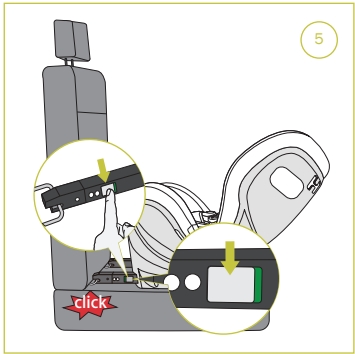

Step 5: As shown in figure 5, insert the two ISOFIX connectors firmly into the ISOFIX fixed point in the car seat with a "clicking" noise. In the meantime, ISOFIX indication window will become green. In order to release ISOFIX connectors, push the green button and the indication window will become red.

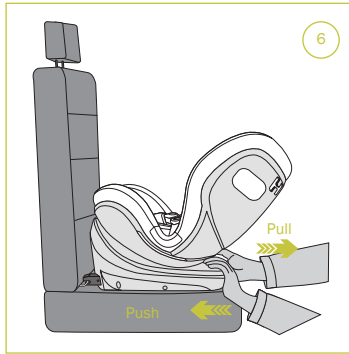

Step 6: As shown in figure 6, one hand pull ISOFIX Setting Handle and the other hand push the baby car seat base to make it fix. Do not need to pull ISOFIX Setting Handle, when ISOFIX seized up.

2. Top Tether Installation for Group 0+I

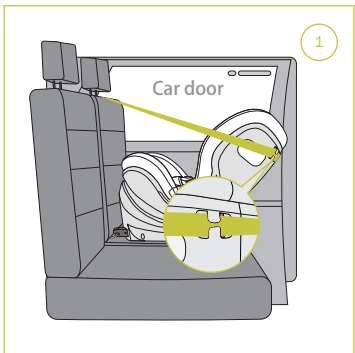

Step1: As shown in figure 1, make the top tether pass through the Guiding slot for rearward facing. Attention: Top tether should install in the other side of the car door to make convenience for children to use.

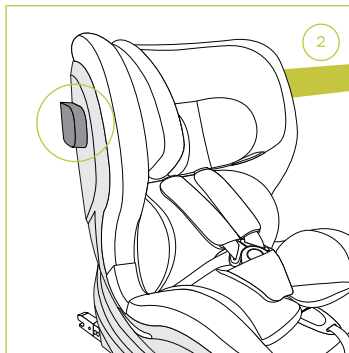

Step 2: As shown in figure 2, open the Side Protection in the other side which not install the top tether (Please refer to P8 - The Function of Side Protection).

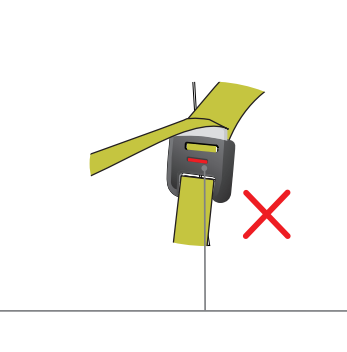
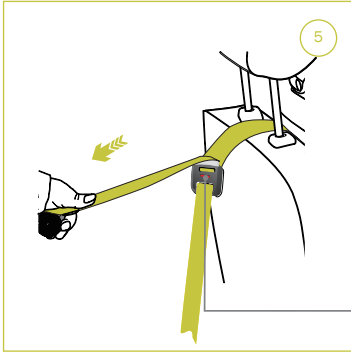
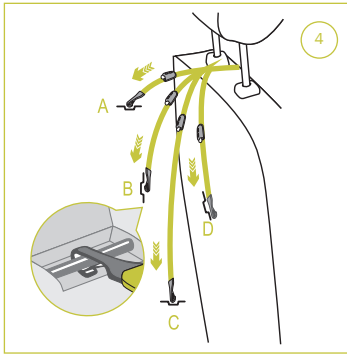
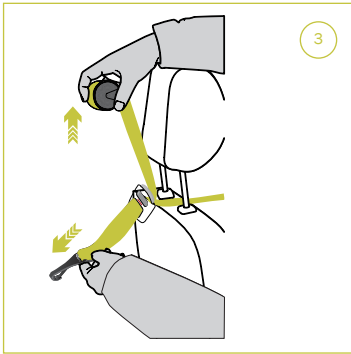

Step 3: As shown in figure 3 and 4, pull out the top tether to go through the middle of car seat headrest and hook the tether anchorage behind (Refer to the User Manual from automaker).

Step 4: As shown in figure 5, tighten the top tether until Top Tether Adjuster shows green. Meanwhile, shake the car seat to check the top tether is tightened favorably and correctly. If you want to release top tether, push the button to make top tether adjuster revolve some angle.

3. Harness Installation for Group 0+

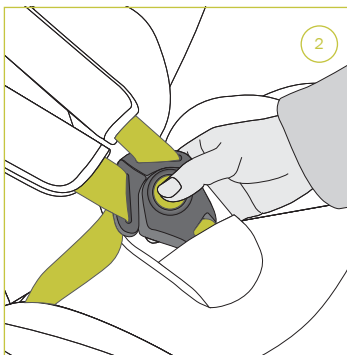
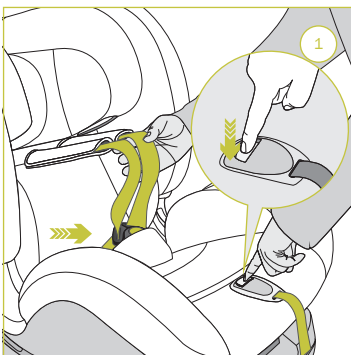

Step 1: As shown in figure 1, press the central adjuster and meanwhile, pull out the harness strap to release shoulder belt.

Step 2: As shown in figure 2, press the red button to open the harness buckle.

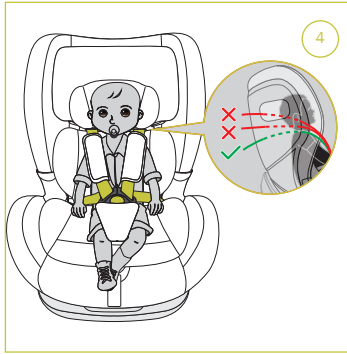
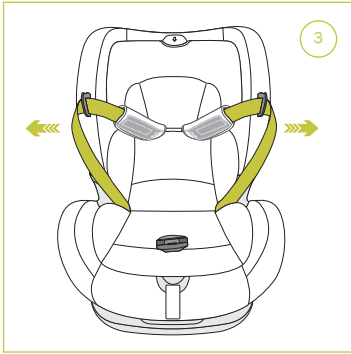

Step 3: As shown in figure 3, pull out both of the shoulder belt to both sides of the seat.

Step 4: As shown in figure 4, have your child sit on the seat to ensure the lap belt restrict the position of pelvis. Please check the shoulder height, the shoulder belts are required to place a little bit higher level of your child's shoulders. Too high or too low may reduce the safety of the children's restraining system.

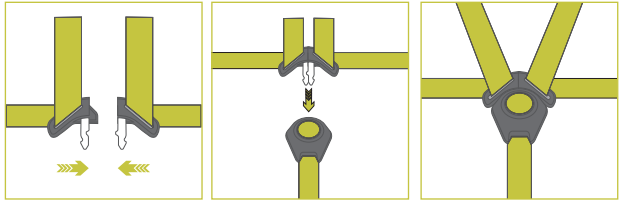
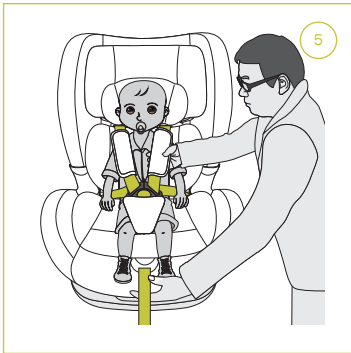

Methods to use harness buckle: guide the two buckle latches together and engage them before putting them into the harness buckle with a click nose. Pull the buckle latches to check whether it is locked well. The buckle latches will be released if you press the red button.

Step 5: As shown in figure 5, pull harness adjustment strap outward to fix child and avoid harness strap to constrict child too much. It is better to make adult palm can insert between harness strap and child's chest. Make sure the tightness is comfortable for your child and ensure the lap belt restrict the position of pelvis. The bottom of both shoulder pads should be close to the same horizontal line and pull down to the lowest position.

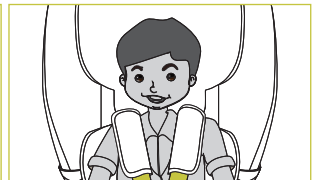
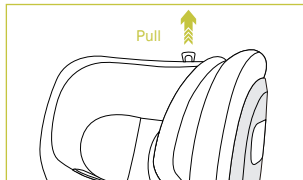
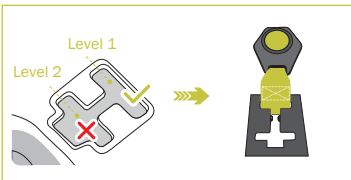

Step 6: 2. As shown in figure 6, in the rearward-facing installation, when the child's weight is less than 18kg, the car seat's right sitting posture is only level 1.

Step 7: As shown in figure 7, pull the Headrest setting handle upward to adjust the headrest to the right position according to different height of children.

Attention: after sitting, adjust the headrest to the right position. In the rearward facing installation, shoulder pads should lower a little bit or even up children's shoulders.



ATTENTION:

1. Only suitable use in the listed vehicles fitted with ISOFIX anchorages systems and approved to ECE Regulation No. 14.
2. The installation for Group I is forward facing and is applied to children from 9 to 18kg.
3. This car seat for Group I has four sitting postures and they are level 2/3/4/5.
4. Important - In the driving condition, baby car seat cannot be lateral using.
5. Don't use forward facing before the child's weight exceeds 9kg!
6. Children less than 9kg need to use 0+ group and 1 group cushion; children between 9-12kg need to use 1 group cushion without 0+ group cushion; children larger than 12kg do not need to use 0+ group cushion and 1 group cushion.

1. ISOFIX Installation for Group I

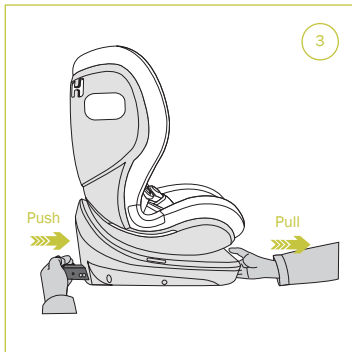
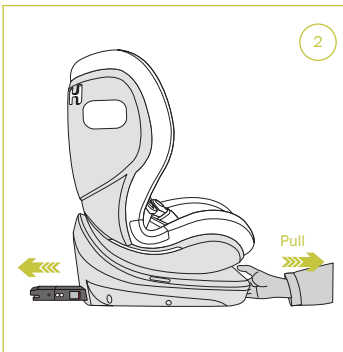
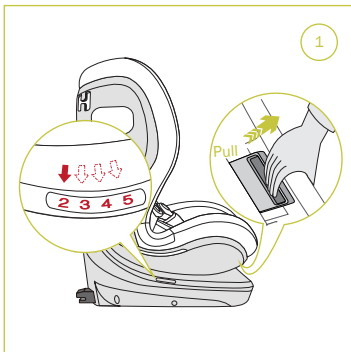

Step 1: As shown in figure 1, rotate car seat to forward facing (Please refer to P8 -The Function of Rotation). Then, pull the Seat Position Adjustment Handle to the suitable level.

Step 2: As shown in figure 2, release ISOFIX connector. Pull ISOFIX settingkey and ISOFIX connector will pop up automatically.

Step 3: As shown in figure 3, if you want to remove the ISOFIX, one hand pull the ISOFIX Setting Handle, the other hand press the ISOFIX connectors into the base.

Step 4: As shown in figure 4, before ISOFIX installation, pick up the top tether from rear cover and pull out some top tether strap. Then, put them in the headrest temporarily.

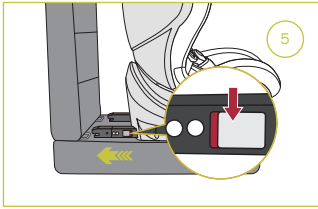

Step 5: As shown in figure 5, before insert the two ISOFIX connectors into the ISOFIX fixed point, ISOFIX indication window is red.

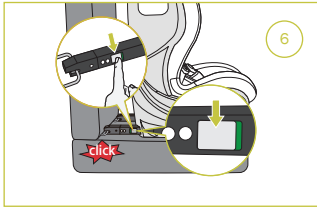

Step 6: As shown in figure 6, insert the two ISOFIX connectors firmly into the ISOFIX fixed point in the car seat with a "clicking" noise. In the meantime, ISOFIX indication window will become green. In order to release ISOFIX connectors, push the green button and the indication window will become red.

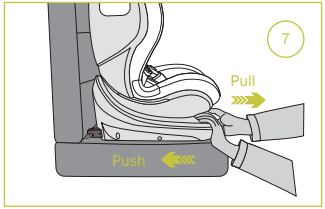

Step 7: As shown in figure 7, one hand pull ISOFIX Setting Handle and the other hand push the baby car seat base to make it fix. Do not need to pull ISOFIX Setting Handle, when ISOFIX seized up.

2. Top Tether Installation for Group I

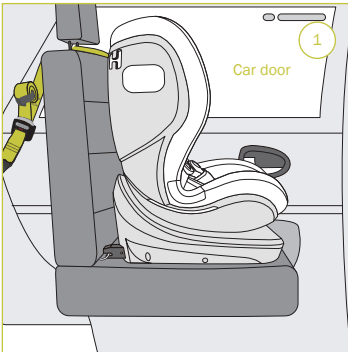

Step 1: As shown in figure 1, make the top tether go through the middle of car seat headrest.

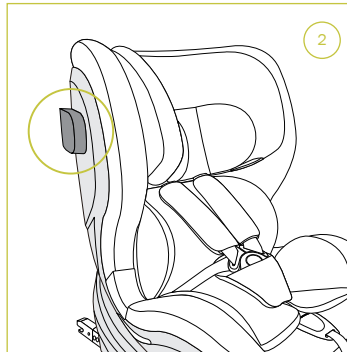

Step 2: As shown in figure 2, open the Side Protection in the side which is near the door (Please refer to P8 - The Function of Side Protection).

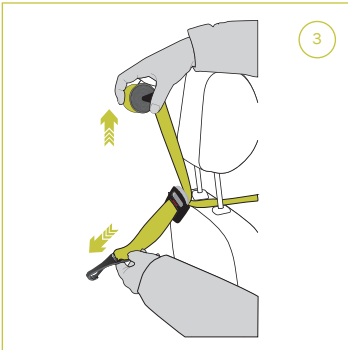

Step 3: As shown in figure 3 and 4, pull out the top tether to go through the middle of car seat headrest and hook the tether anchorage behind (Refer to the User Manual from automaker. If necessary, you can remove the car headrest to make it easy to install baby car seat).

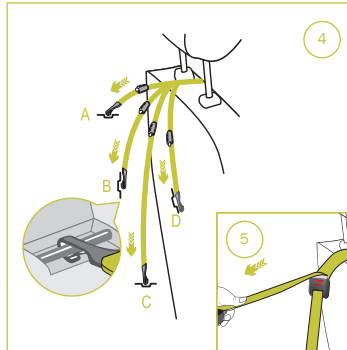

Step 4: As shown in figure 5, tighten the top tether until Top Tether Adjuster shows green. Meanwhile, shake the car seat to check the top tether is tightened favorably and correctly. If you want to release top tether, push the button to make top tether adjuster revolve some angle.

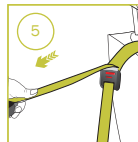



3. Harness Installation for Group I

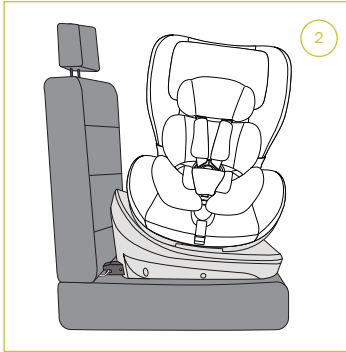
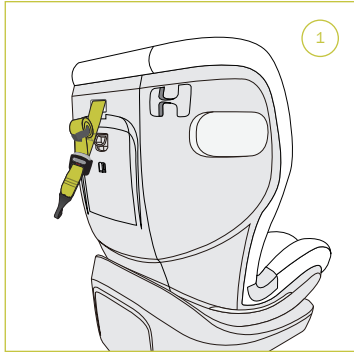

Step 1: As shown in figure 1, pull out some top tether strap.

Step 2: As shown in figure 2, rotate the car seat to the 90 degree ((Please refer to P8 -The Function of Rotation).

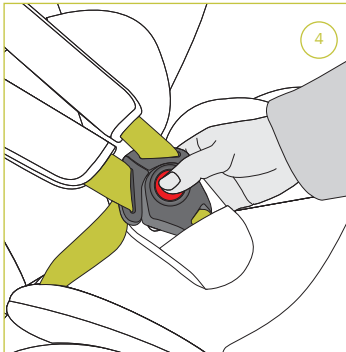
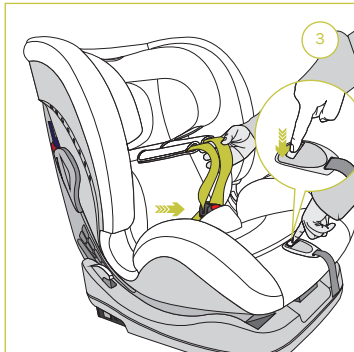

Step 3: As shown in figure 3, press the central adjuster and meanwhile, pull out the harness strap to release shoulder belt.

Step 4: As shown in figure 4, press the red button to open the harness buckle.

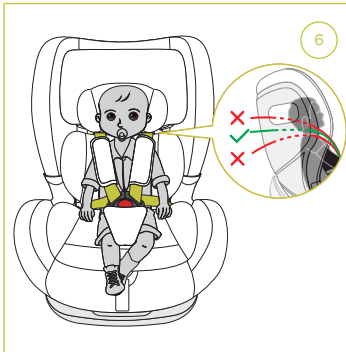
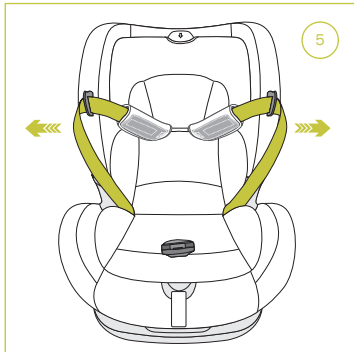

Step 5: As shown in figure 5, pull out both of the shoulder belt to both sides of the seat.

Step 6: As shown in figure 6, have your child sit on the seat to ensure the lap belt restrict the position of pelvis. Please check the shoulder height, the shoulder belts are required to place a little bit higher level of your child's shoulders. Too high or too low may reduce the safety of the children's restraining system.

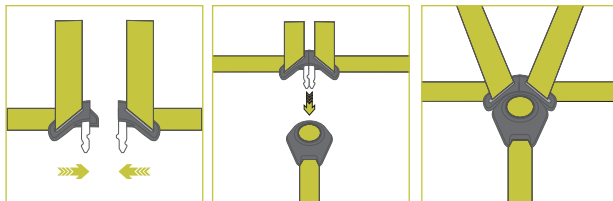
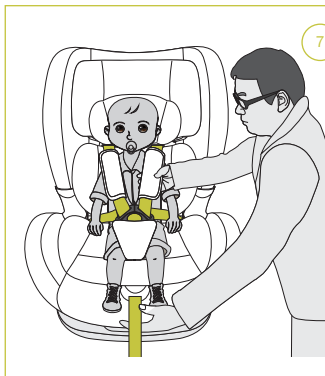

Methods to use harness buckle: guide the two buckle latches together and engage them before putting them into the harness buckle with a click nose. Pull the buckle latches to check whether it is locked well. The buckle latches will be released if you press the red button.

Step 7: As shown in figure 7, pull harness adjustment strap outward to fix child and avoid harness strap to constrict child too much. It is better to make adult palm can insert between harness strap and child's chest. Make sure the tightness is comfortable for your child and ensure the lap belt restrict the position of pelvis.

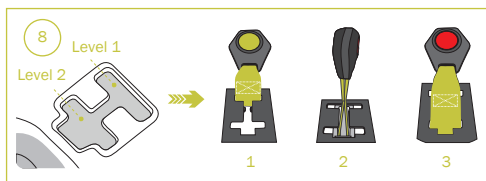

Step 8: As shown in figure 8, Children who less than 10kg should use Level 1, and children who equal 10kg or over 10kg should use Level 2. Before adjustment, loosen five-point safety belt and open buckle. Then twist the strap to go through a vertical slot and make sure buckle are fixed in the slot.

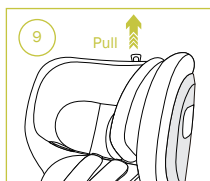

Step 9: As shown in figure 9, pull the Headrest setting handle upward to adjust the headrest to the right position according to different height of children.

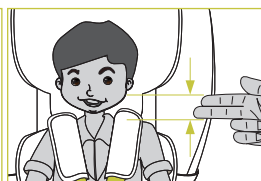

Attention: after sitting, adjust the headrest to the right position. In the forward facing installation for Group I, shoulder pads should higher a little bit. One or two fingers is the best distance from the bottom of headrest to child's shoulders.

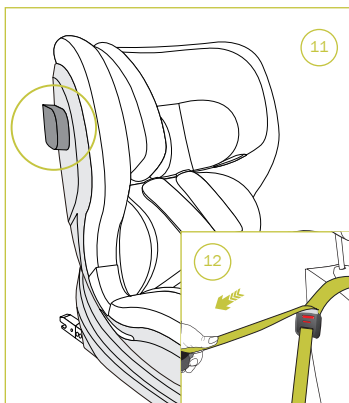
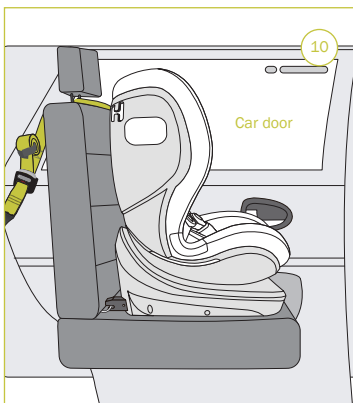

Step 10: As shown in figure 10, rotate car seat to forward facing (Please refer to P8 -The Function of Rotation).

Step 11: As shown in figure 11, open the Side Protection in the side which is near the door (Please refer to P8 - The Function of Side Protection).

Step 12: As shown in figure 12, tighten the top tether until Top Tether Adjuster shows green. Meanwhile, shake the car seat to check the top tether is tightened favorably and correctly. If you want to release top tether, push the button to make top tether adjuster revolve some angle.

5-Point Harness Removal

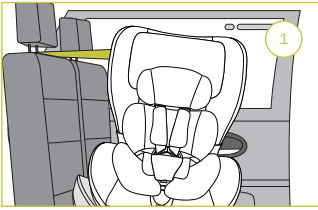

Step 1: As shown in figure 1, loose the top tether strap and rotate the car seat to the 90 degree (Please refer to P8 -The Function of Rotation).

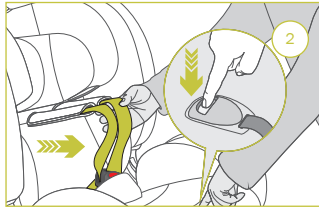

Step 2: As shown in figure 2, press the central adjuster and loose the shoulder belt. Then, adjust the headrest to the suitable position.

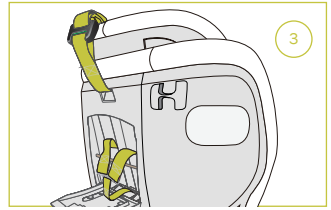

Step 3: As shown in figure 3, tighten the top tether and put it in the headrest temporarily. Then, open the rear cover.

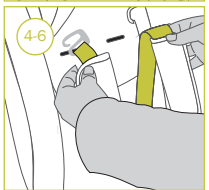
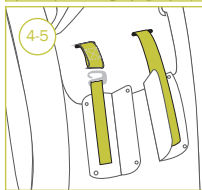
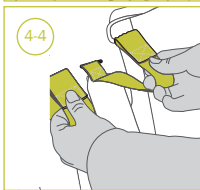
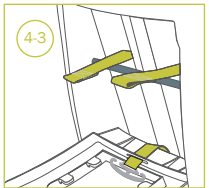
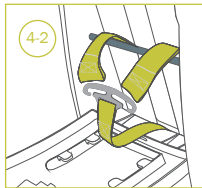
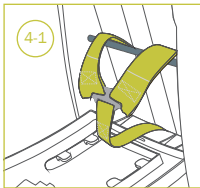
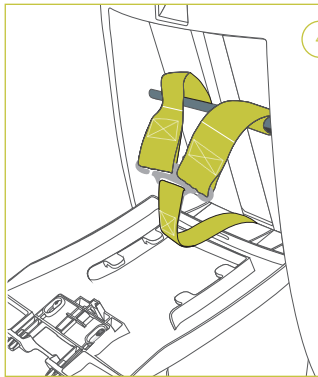

Step 4: remove the shoulder pads: As shown in figure 4, separate the shoulder belts with strap yoke according to the figure 1-2-3-4. Then, make strap yoke pass through the hole in the rear cover, put it into the storage slot and draw out the belt forward. According to figure 5 and 6, open the shoulder pads, separate shoulder belts with strap yokes, then draw out the shoulder pads.

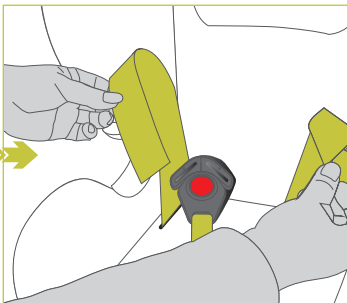
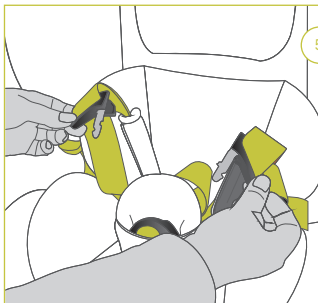

Step 5: As shown in figure 5, open harness buckle, put the buckle pad and cushion aside.

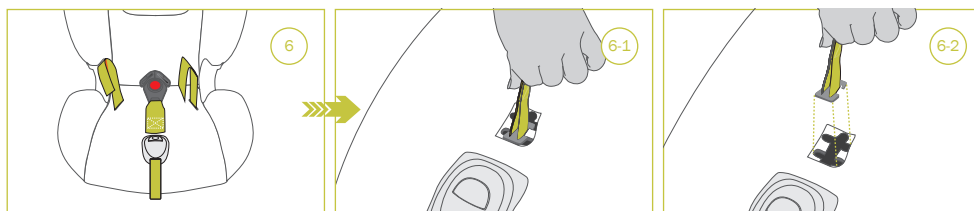

Step 6: As shown in figure 6, separate the harness buckle and car seat.

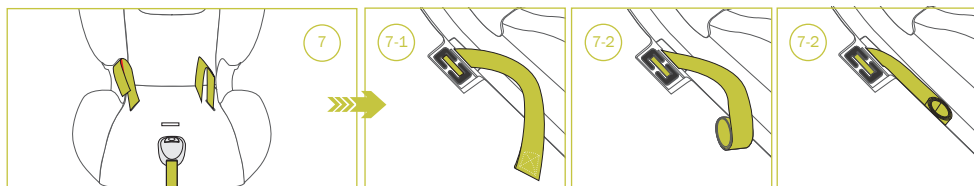

Step 7: Shoulder strap storage: As shown in figure 7 (1-2-3), roll up the strap and place into the groove in the base.

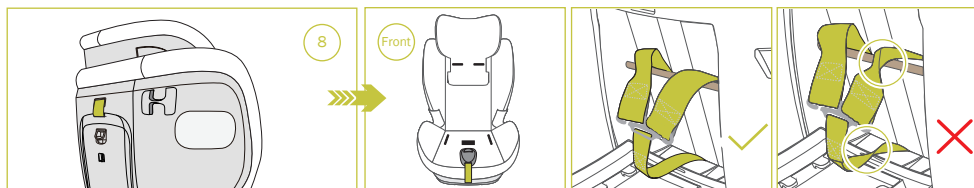

Step 8: Put the top tether into the rear cover and close it. Please storage all removal parts. As shown in above image, finish removing the 5-point safety belt.

Attention: When you install shoulder belt and harness yoke, do not twist the strap.

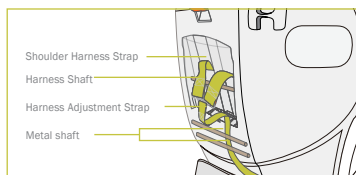

As shown in above figure, when you install shoulder straps back, you must make the shoulder straps pass the harness shaft & harness adjustment strap do not pass it.

Group II+III (15-36kg) Installation and Using method

ATTENTION:

1. There is only one position level for Group II+III and it is level 2.
2. The installation for Group II+III is forward facing and is applied to children from 15 to 36kg.
3. Before using Group II+III, please remove the 5-point safety belt and cushion.
4. Pull the belt in the buckle tightly to make sure buckle in the right position.
5. Universal Installation is only suitable use in the listed vehicles fitted with 3-point belt and approved to ECE Regulation No. 16.
6. Semi-Universal Installation is only suitable use in the listed vehicles fitted with ISOFIX anchorages systems and approved to ECE Regulation No. 16.

1. UNIVERSAL II+III (15-36kg): 3-POINT BELT

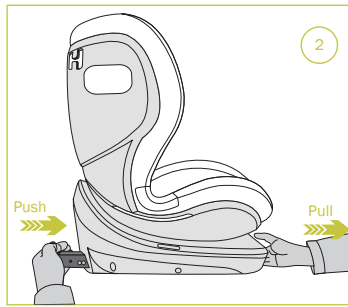
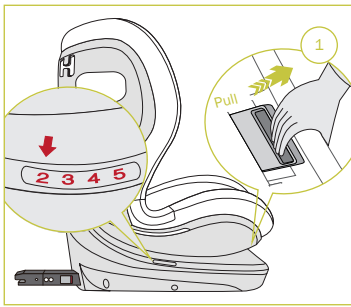

Step 1: As shown in figure 1, rotate car seat to forward facing (Please refer to P8 -The Function of Rotation). Then, pull the Seat Position Adjustment Handle to the level 2.

Step 2: As shown in figure 2, one hand pull the ISOFIT Setting Handle, the other hand press the ISOFIT connectors into the base.

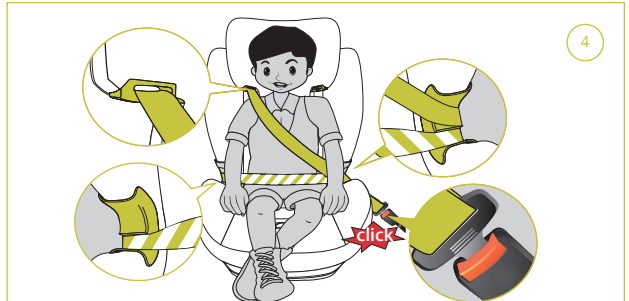
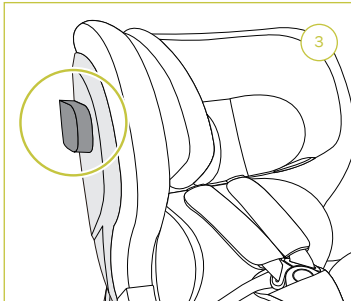

Step 3: As shown in figure 3, open the Side Protection in the side which is near the door (Please refer to P8 - The Function of Side Protection).

Step 4: As shown in figure 4, have your child sit on the seat and adjust headrest to the comfortable position. Then make the oblique belt through the guiding hook for Group II and III, horizontal belt through two harness guiders and insert car belt tongue to car buckle with click sound. Finally, make sure the lap belt can restrict the position of pelvis.

2. SEMI-UNIVERSAL II+III (15-36kg): ISOFIT+3-POINT BELT

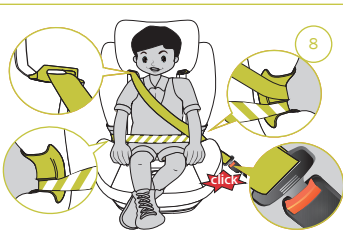
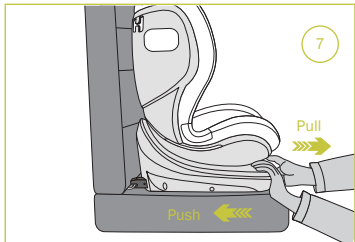
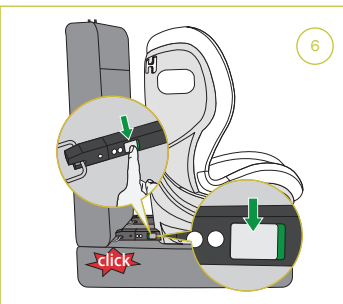
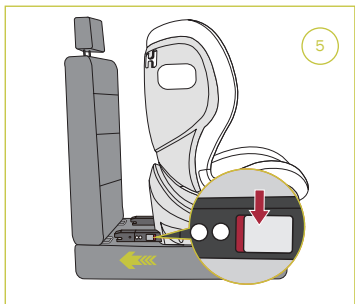
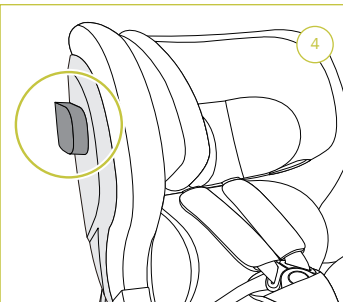
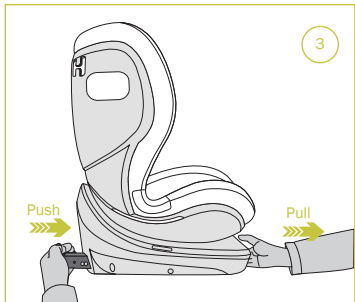
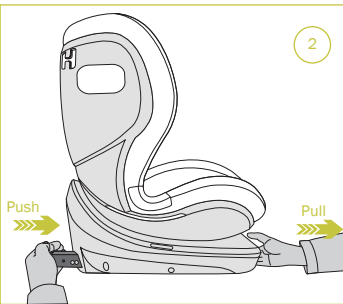
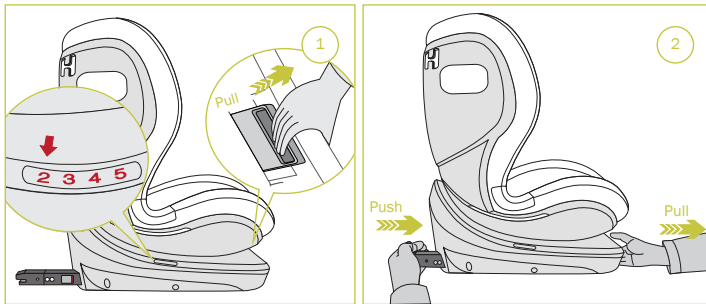

Step 1: As shown in figure 1, rotate car seat to forward facing (Please refer to P8 -The Function of Rotation). Then, pull the Seat Position Adjustment Handle to the level 2.

Step 2: As shown in figure 2, release ISOFIX connector. Pull ISOFIX settingkey and ISOFIX connector will pop up automatically.

Step 3: As shown in figure 3, if you want to remove the ISOFIT, one hand pull the ISOFIT Setting Handle, the other hand press the ISOFIT connectors into the base.

Step 4: As shown in figure 4, open the Side Protection in the side which is near the door (Please refer to P8 - The Function of Side Protection).

Step 5: As shown in figure 5, before insert the two ISOFIT connectors into the ISOFIT fixed point, ISOFIT indication window is red.

Step 6: As shown in figure 6, insert the two ISOFIT connectors firmly into the ISOFIT fixed point in the car seat with a "clicking" noise. In the meantime, ISOFIT indication window will become green. In order to release ISOFIT connectors, push the green button and the indication window will become red.

Step 7: As shown in figure 7, one hand pull ISOFIT Setting Handle and the other hand push the baby car seat base to make it fix. Do not need to pull ISOFIT Setting Handle, when ISOFIT seized up.

Step 8: As shown in figure 8, have your child sit on the seat and adjust headrest to the comfortable position. Then make the oblique belt through the guiding hook for Group II and III, horizontal belt through two harness guiders and insert car belt tongue to car buckle with click sound. Finally, make sure the lap belt can restrict the position of pelvis.

Removing the Cover

1. Removing the cover of car body

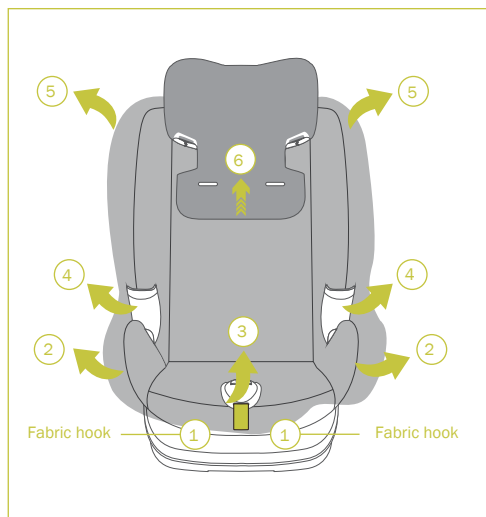

Removing the cover of car body: As shown in left figure, remove the fabric cover according to the order of 1, 2, 3, 4, 5 (There are hooks in figure 1).

ATTENTION: When you are ready to refit, make the steps in the opposite order.

2. Removing the cover of headrest

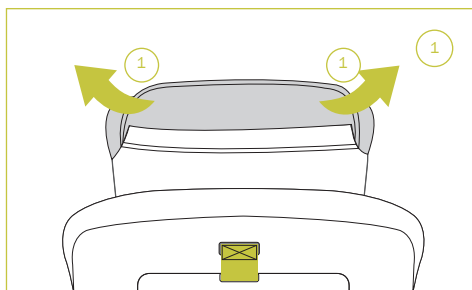

Step 1: As shown in figure 1, adjust the headrest to the right height firstly and then remove the headrest cover from the frame.

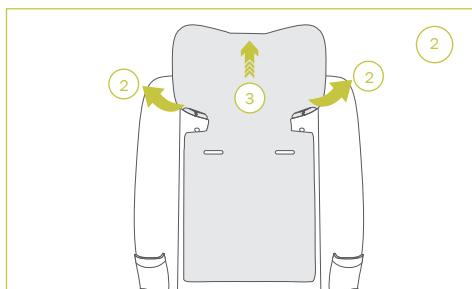

Step 2: As shown in figure 2, separate the elastic from the headrest. Then, remove the cover as shown in Arrow 3.

Cleaning and Maintenance

- Regularly check all important parts for damage. Make sure that the mechanical components in particular are all in perfect working order. If there is damage about your child safety seat in the event of an accident, in this case the safety seat must be replaced.
- Store the child safety seat in a safe, dry place when it will not be used for an extended period of time.
- Brush away loose debris using a soft bristled brush to clean the safety belt and plastic components, and then ventilate or dry them.
- If food or beverage drips on your seat belt, thoroughly rinse it using warm water and then ventilate or dry it.
- Remove and wash the cover see the instructions of cleaning.
- If wash the cover in the first time, the cover might fade a little bit, It is a normal phenomenon.

Washing Instructions

Do not use solvents, chemical cleaners and lubricants



Hand Wash
using the water
under 30°C



Do not Bleach



Do not
Machine Dry



Do not Iron